



# Diamond Side Entry, Y Type & Pump Protection Filters Installation & Maintenance - ATEX

## **IMPORTANT INFORMATION** Please read carefully before installing your unit.

This document should be used in conjunction with the DPL Installation & Operating / Maintenance Instructions accordingly.

### **Additional Information for ATEX compliant filters:**

ATEX compliant filters that support the Ex compliance symbol pictured below require an additional check when maintenance or installation is performed. A conductivity test is essential and must be performed to ensure safe operation of the unit in hazardous environments. When filters are dismantled for weld in place installation or for maintenance it is important that they are correctly reassembled and tested for correct conductivity as depicted below.

### **Conductivity Test:**

On completion of the assembly procedure, as described in the separate Installation and Maintenance Instructions, a multi-meter should be used to check that electrical conductivity exists between the filter body and the filter end cap as shown below. If no conductivity exists, the filter should not be used.

**Temperature Rating:** Filters carrying the Ex symbol as below are marked T6...T4, 85°C...135°C.

This temperature range is provided to cover process media temperatures for filters fitted with seal material as follows:

Max Operating Temperature: Nitrile 85°C. EPDM, Silicone, Viton & PTFE: Max Operating Temperature 135°C.

### **Important Note:**

PIPEWORK THAT IS TO BE CONNECTED TO ATEX COMPLIANT FILTERS MUST BE EARTHED.



ATEX Compliance Symbol.

PUMP PROTECTION FILTER

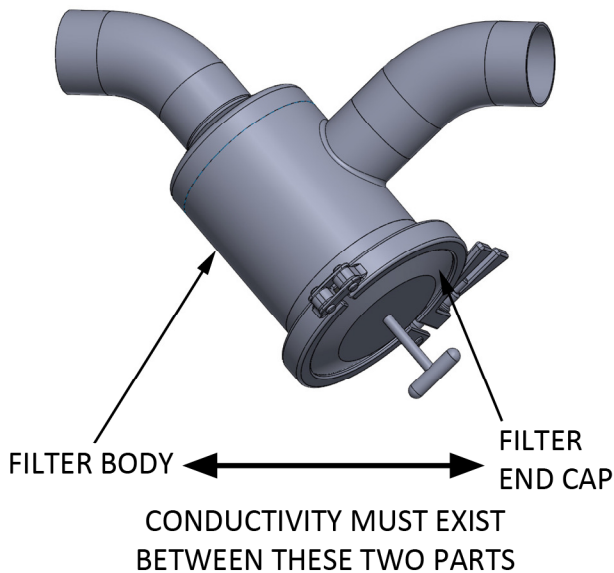

SIDE ENTRY FILTER

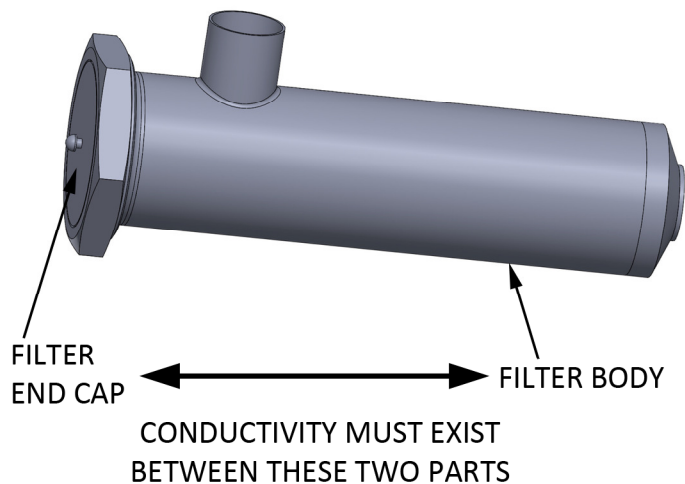

Note: Side Entry Filter depicted.  
Same principle applies for Y Type filters