



Diamond 3 Piece Ball Valve Maintenance Instructions (KB4LV)

Spares Kits:

SIZE	PART NUMBER	THIS KIT
1.0"	KB4LV10	_____
1.5"	KB4LV15	_____
2.0"	KB4LV20	_____
2.5"	KB4LV25	_____
3.0"	KB4LV30	_____

IMPORTANT: Please read carefully before commencing any work on this valve:

1. Ensure that the line pressure is zero and fully drained and that all pneumatic and power supplies are turned off and isolated.
2. When operating the valve ensure that fingers are clear of moving parts to avoid injury.
3. Gaskets and seals should be stored away from UV light to increase shelf life.
4. Ensure that pipes and connections are properly aligned before mounting the valve in position to avoid undue stress and leakage.
5. Always operate the valve open and closed several times before use to ensure correct function.
6. The user should adopt a maintenance programme for valves depending on frequency of use and application particulars. DPL recommends seal replacement at least every two years.

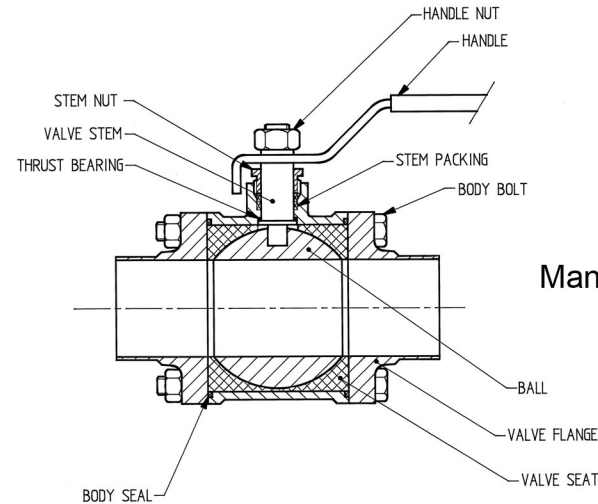

DISMANTLING PROCEDURE:

1. Ensure that the process line and valve is drained and pressure is zero. If an actuator is fitted ensure that the pneumatics and power supply are turned off and isolated and make a note of the open / closed orientation of the valve / actuator. Remove the actuator from the valve. When re-fitting the actuator, following maintenance, the noted orientation should be maintained.
2. Remove the valve from the line and hold securely in a soft jaw bench vice. If the valve is welded in-line, go to section 3.
3. Using two appropriate size spanners, loosen the four valve body bolts and remove the nuts.
4. The four bolts can now be removed, taking care to make sure that the centre section of the valve body is held / supported as this will become loose once the bolts are removed.
5. Once all four bolts are out, carefully remove the valve centre section containing the ball and all seals (white PTFE).
6. Place the valve centre section on the bench. With the ball in the closed position, the ball should be pushed out of the centre section by hand, and the body seals and valve seats removed.
7. Loosen and remove the stem nut. The valve stem can now be pushed down into the body and removed. The thrust washer and stem packing are now accessible. The seals can now be replaced.
8. **RE-ASSEMBLY:** The assembly procedure is the dismantling procedure in reverse order. Take care when assembling the valve as the PTFE seals are easily damaged. The following precautions should be taken:
9. The stem nut should be tightened adequately, but not over-tightened. Use only enough force to form a seal, do not use excessive force as this will crush the PTFE stem packing. Turn the valve stem then re-adjust accordingly.
10. When re-fitting the valve centre section between the valve flanges, ensure cleanliness of the mating faces at all times.
11. With the valve centre section back in-place, the four body bolts should be gradually tightened. Tighten each bolt a little at a time. Tighten the bolts diagonally so that an even pressure is applied. Make sure that the body seals are correctly located to avoid damage.
12. Ensure that the bolts are fully tight. Keep fingers clear of moving parts and operating the valve open / closed to check for correct operation. Re-fit the actuator (if required). Ensure that the valve is in the correct open / closed orientation on re-fitting.
13. Valves should be pressure tested with water, if possible, following maintenance. Follow your in-house test procedures accordingly, the valve maximum operating pressure is 10 bar.