



Diamond Series 3 Pressure Relief Valve Installation & Maintenance - ATEX

IMPORTANT INFORMATION Please read carefully before installing your unit
This document should be used in conjunction with the DPL Installation & Operating Instructions / Maintenance Instruction accordingly.

Additional Information for ATEX compliant Valves:

ATEX compliant valves that support the compliance symbol pictured below are fitted with additional components that are essential to the safe operation of the unit in hazardous environments. When the valves are disassembled for weld in place, installation or for maintenance it is important that they are correctly reassembled and electrical conductivity tested as depicted and described below. If no conductivity exists, the valve should not be used. The image below is an assembly illustration of the Pressure Relief Valve showing the additional ATEX components in situ:

Important Note: Pipework that is to be connected to DPL ATEX compliant valves must be earthed, ATEX PRV handles must not be fitted with the blue sleeve.

IMPORTANT

The ATEX PRV valve handle (not shown) must not be fitted with the DPL blue sleeve. The handle must be metal only.

EARTH SCREW (ATEX SPECIFIC PART)

EARTHING SPRING (ATEX SPECIFIC PART)



ATEX Compliance Symbol.

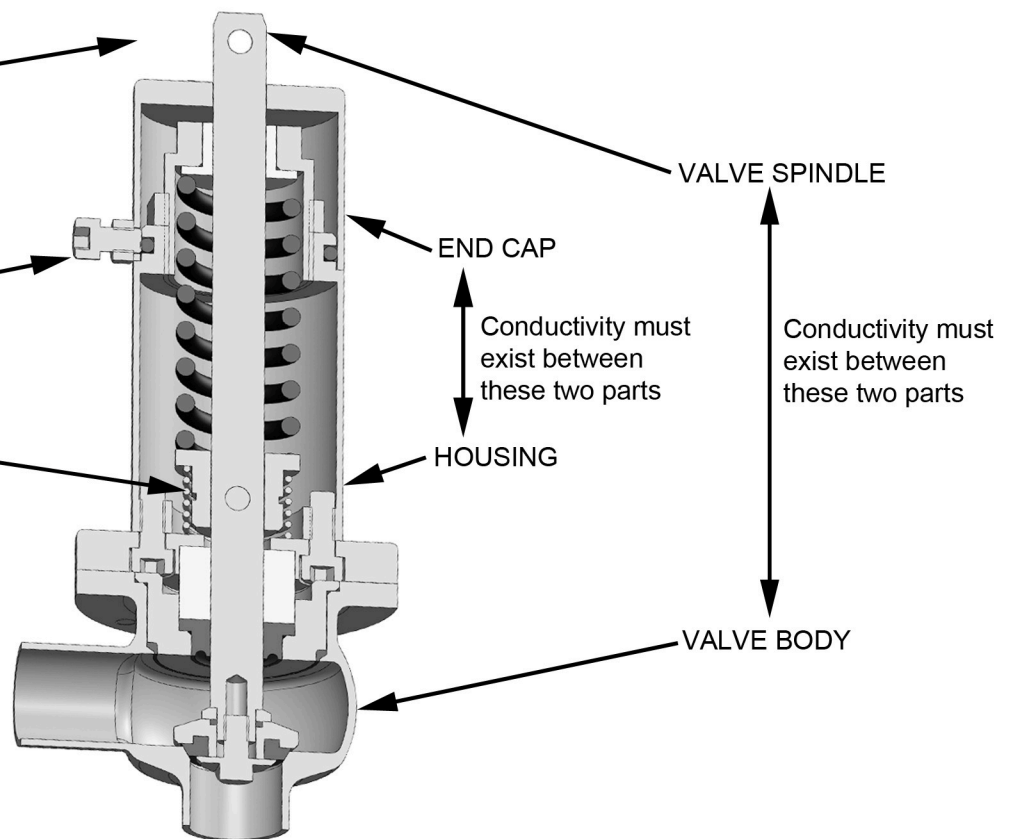

Electrical Conductivity Check: There is normally no need to remove the ATEX earthing spring or earth screw shown above when performing routine maintenance or when installing the valve, as per the separate instructions. If it is necessary to fully dismantle the valve then there is the additional operation of removing and then replacing the earthing spring and earth screw on re-assembly. The earth screw should also always be re-tightened on re-assembly and following pressure adjustment of the valve. Once the valve is assembled, electrical conductivity must be checked without the handle in place, between the valve body and valve spindle and between the valve housing and end cap (using a multi-meter). The location of the parts where conductivity must exist between, is shown above. If conductivity does not exist, the valve must not be used.

Temperature Rating: Valves carrying the Ex symbol as shown above are marked T6...T4, 85°C...135°C. This temperature range is provided to cover process media temperatures for valves fitted with seal material as follows:
Nitrile: Max Operating Temperature 85°C.
EPDM, Silicone, Viton, PTFE: Max Operating Temperature 135°C.



www.dpluk.co.uk

a stainless technologies company

Call us: 01799 58 2440 email us: dairypipelines@dpluk.co.uk

Visit us at: www.dpluk.co.uk Unit 1 Dencora Park, Shirehill, Saffron Walden. CB11 3GB