



The Diamond Three Piece Ball Valve (KB4LV)

INSTALLATION & OPERATING INSTRUCTIONS

IMPORTANT - PLEASE READ CAREFULLY BEFORE INSTALLING YOUR VALVE

Page 1 of 2

INSTALLATION

A process system can generally be associated with many varying conditions. When designing the system, aggressive conditions such as water hammer, pressure shock and excessive vibration should be avoided to prevent damage to the valve and the process system. When installing the Ball Valve into a pipework system, careful consideration must be made to ensure good alignment and adequate support for the valve by means of pipe-clips and framework etc. Consideration must also be made for maintenance requirements. Allow enough room to enable access to the valve following installation. Once in-place, operate the valve to ensure correct open / closed orientation can be achieved.

VALVES WITH PLAIN BUTT WELD ENDS

If welding the valve body directly into the pipeline the valve should be disassembled and the centre section containing the ball and seals removed from the valve (see page 2). This will prevent heat damage to the valve seals and other internal components. When welding ensure correct alignment and squareness of the butt weld joints to avoid stress in the pipe / valve bodies. This is important to ensure correct operation and leak tightness of the valve once assembled. Gas backed TIG welding is recommended. A minimum weld bead should be produced to reduce the risk of heat distortion of the valve body parts. The valve must be allowed to cool following welding before re-assembly. Consideration should be made to future maintenance access of the valve once welded in place. Once fitted in-place, operate the valve to ensure correct open / closed orientation can be achieved. Valves should be pressure tested with water, if possible, following installation. Follow your in-house test procedures accordingly, the valve maximum operating pressure is 10 bar.

SPARES KITS

The user should establish a maintenance programme for valves depending upon the type of product and frequency of the valve use. We recommend that the seals be replaced at least on a 2 yearly basis. Spares kits complete with maintenance instructions are available from the DPL Sales Team. Spares kit part numbers are given below:

Valve Size	Spares Kit Part No.
1.0" Valve	KB4LV10
1.5" Valve	KB4LV15
2.0" Valve	KB4LV20
2.5" Valve	KB4LV25
3.0" Valve	KB4LV30

PRESSURE EQUIPMENT DIRECTIVE 2014/68/EU

Article 4, paragraph 3 - Sound Engineering Practise (SEP) applies to this product for non-group 1 use and at pressures not exceeding 10 bar.



www.dpluk.co.uk

a stainless technologies company

Call us: 01799 58 2440 email us: dairypipelines@dpluk.co.uk

Visit us at: www.dpluk.co.uk Unit 1 Dencora Park, Shire Hill, Saffron Walden. CB11 3GB



The Diamond Three Piece Ball Valve (KB4LV)

INSTALLATION & OPERATING INSTRUCTIONS

IMPORTANT - PLEASE READ CAREFULLY BEFORE INSTALLING YOUR VALVE

WELD IN PLACE PROCEDURE

Disassemble as described below prior to welding.

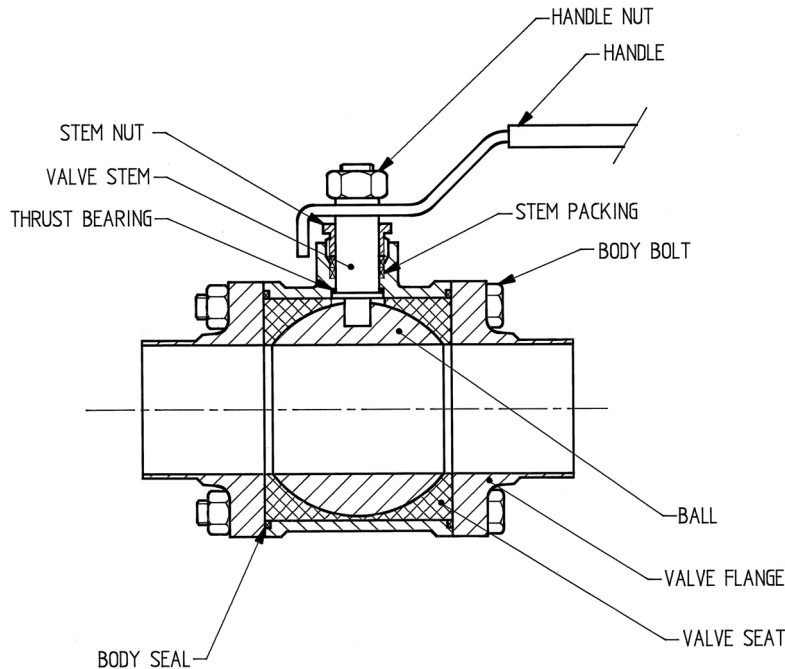

1. Prepare the tube and valve ends for welding as per your company welding procedure.
2. Hold the valve securely in a vice, using soft jaws.
3. If an actuator is fitted, this must first be removed from the valve. Make a note of the open / closed position of the valve so that the valve can be positioned in the same orientation prior to re-fitting the actuator, following this procedure.
4. Using two appropriate size spanners, loosen the four body bolts and remove the nuts.
5. The four bolts can now be removed, taking care to make sure that the centre section of the valve body is held / supported as this will become loose once the bolts are removed.
6. Once all four bolts are out, remove the valve centre section containing the ball and all seals (white PTFE).
7. The valve end flanges can now be welded in-place accordingly, use a minimum weld bead to keep heat dissipation to a minimum, to avoid distortion of the valve flanges. Follow your company weld procedures. If the pipework is fixed, a spacer should be used between the valve flanges to ensure the correct gap is allowed for, for the centre body section. Ensure that the valve flanges are welded parallel to each other and that the bolt holes are aligned. Misalignment may result in leakage / valve operation failure once re-assembled.
8. Allow the valve flanges to cool following welding before re-assembly.
9. Re-fit the valve centre section between the two valve flanges, ensuring cleanliness of the mating faces at all times. With the centre section in-place, replace the four bolts and tighten the nuts. Bolt tightening should be done gradually, tightening each bolt a little at a time. Tighten the bolts diagonally so that an even pressure is applied as the valve flanges come together. Make sure that the body seals are correctly located to avoid damage.
10. Ensure that the bolts are fully tight. Keep fingers clear of moving parts and operating the valve open / closed to check for correct operation. Re-fit the actuator (if required).
11. Valves should be pressure tested with water, if possible following installation. Follow your in-house test procedures accordingly, the valve maximum operating pressure is 10 bar.