



# The Diamond Butterfly Valve

## INSTALLATION & OPERATING INSTRUCTIONS IMPORTANT - PLEASE READ CAREFULLY BEFORE INSTALLING YOUR VALVE

### STORAGE

If this valve is not to be used soon after purchase it should be stored in the open position. Over a period of time the seal may form a compression set around the spindle disc if left in the closed position. This may make the initial breakout opening torque of the valve higher than normal. If stored for extended periods, valves should be operated manually open and closed 10 times before use to ensure smooth operation.

### INSTALLATION

When installing the Butterfly Valve into a pipework system, careful consideration must be made to ensure good alignment and adequate support for the valve by means of pipe-clips and framework etc. If self drainage is required consideration must be made to the valve installation orientation. The pipework / valve should be mounted at an appropriate angle if in the horizontal position to enable adequate drainage.

### ATEX VALVES

Please refer to the separate document "Diamond Butterfly Valves Installation & Maintenance - ATEX" to be used in conjunction with this document when installing or maintaining valves that support the "Ex" symbol. This additional information is essential to the safe operation of your valve in hazardous environments.

CONNECTING PIPEWORK MUST BE EARTHED.

### VALVES WITH PLAIN BUTT WELD ENDS

If welding the valve body directly into the pipeline the valve should be partly disassembled and all seal components removed from the valve bodies (see page 2). This will prevent heat damage to the valve seals and other internal components. When welding ensure correct alignment and squareness of the butt weld joints to avoid stress in the pipe / valve bodies. This is important to ensure correct operation and leak tightness of the valve once assembled. Gas backed TIG welding is recommended. A minimum weld bead should be produced to reduce the risk of heat distortion of the valve flanges. The valve must be allowed to cool following welding before re-assembly. Consideration should be made to future maintenance access of the valve once welded in place.

### MANUAL VALVES (LEVER OPERATED)

DPL Offer two handle types, operation is as follows:

Blue Nylon On-Off style handle: Place thumb on the protruding black thumb nut and with the rest of the hand, grip the handle and lift then turn through 90 degrees.

Stainless Steel 5 Position Handle: Lift the lever to the handle, turn handle to the desired opening position, release the lever into the closest locking notch.

### ACTUATED VALVES

Please see the separate Installation and Operating Instructions for Diamond Actuators.

### SPARES KITS

The user should establish a maintenance programme for valves depending upon the type of product and frequency of the valve use. Spares kits complete with maintenance instructions are available from the DPL Sales Team. Spares kit part numbers are given below:

Valve Size	Spares Kit Part No.	Seal Material Suffix
1.0" Valve (incl 0.5" & 0.75")	KDFD10 *	* Denotes the seal material suffix: E - EPDM V - Viton N - Nitrile S - Silicone
1.5" Valve	KBFD15 *	
2.0" Valve	KBFD20 *	
2.5" Valve	KBFD25 *	
3.0" Valve	KBFD30 *	
4.0" Valve	KBV40 *	

### PRESSURE EQUIPMENT DIRECTIVE 2014/68/EU

Article 4, paragraph 3 - Sound Engineering Practise (SEP) applies to this product for non-group 1 use and at pressures not exceeding 10 bar.

Continued on page 2....





# The Diamond Butterfly Valve

## INSTALLATION & OPERATING INSTRUCTIONS IMPORTANT - PLEASE READ CAREFULLY BEFORE INSTALLING YOUR VALVE

### WELD IN PLACE PROCEDURE

Page 2 of 2

Disassemble as shown below depending on the valve configuration

1. First remove the handle type A or type B as shown.

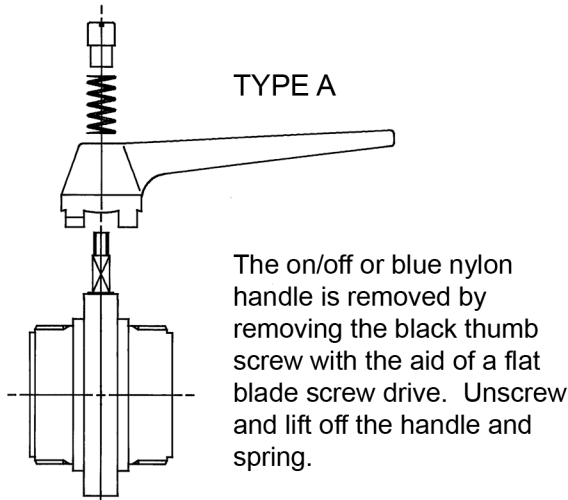

The stainless steel handle is removed by holding the valve in a vice as shown. Using a pin punch, remove the handle retaining roll pin. The handle parts can then be separated from the valve body.

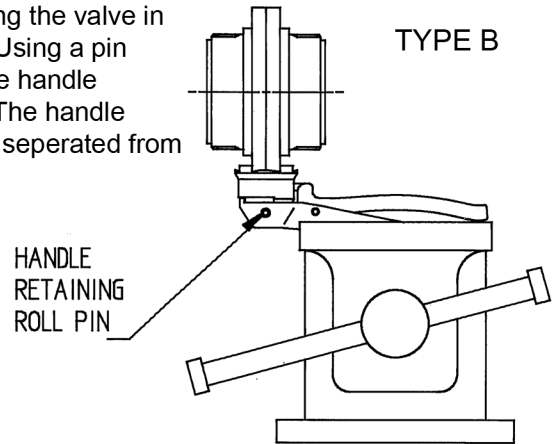

2. Or remove the actuator (if fitted).

To remove the actuator: First place the valve body in a vice. Undo and remove the 2 off M5 bracket bolts then simply lift off the actuator as shown. Note that the red position indicator fitted to the actuator coupling is in-line with the valve disc.

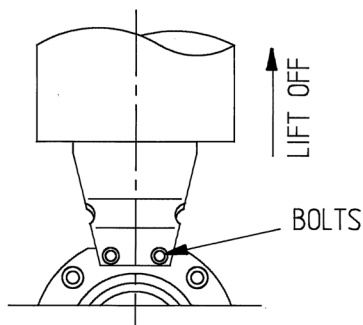

3. Using an allen key undo and remove the M6 cap screws. Loosen the screws a little at a time, diagonally at first as the valve halves separate. Once separated, remove the gasket / paddle / bottom cap assembly as shown. Place to one side.

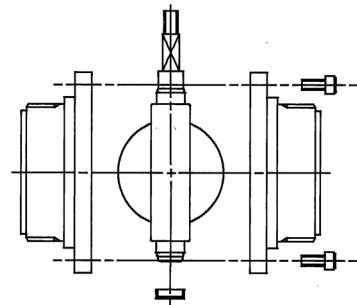

4. Prepare the pipe and valve ends for welding as per your company welding procedure and weld accordingly giving consideration to future maintenance access of the valve once welded in place. Once cooled, the valve can be re-assembled, noting correct bearing orientation as shown.

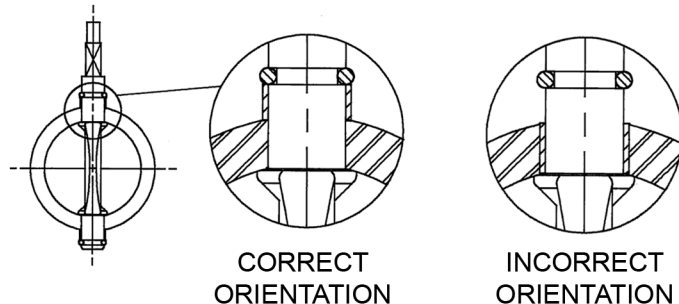

5. Tighten the bolts in a diagonal sequence as shown below. Once fully tight, replace the handle or actuator accordingly. Operate the valve open and closed several times to ensure correct operation before use. If fitted with an actuator, ensure that the red position indicator is in-line with the valve disc as noted in stage 2 above.

