



Diamond Three Way Ball Valve

Maintenance Instructions

SEAL KITS:

SIZE	SEAL KIT PART No.	THIS KIT
0.5"	KB3WLV05	_____
0.75"	KB3WLV07	_____
1.0"	KB3WLV10	_____
1.5"	KB3WLV15	_____
2.0"	KB3WLV20	_____
2.5"	KB3WLV25	_____
3.0"	KB3WLV30	_____

IMPORTANT Please read carefully before commencing any work on this valve:

1. Ensure that the line pressure is zero and fully drained and that all pneumatic and power supplies are turned off and isolated.
2. When operating the valve ensure that fingers are clear of moving parts to avoid injury.
3. Gaskets and seals should be stored away from UV light to increase shelf life.
4. Ensure that pipes and connections are properly aligned before mounting the valve in position to avoid undue stress and leakage.
5. Valves should be stored in the open position to prevent seal set around the valve ball. If stored in the mid-position seal set will increase the closing torque when first operating the valve.
6. Always operate the valve open and closed several times before use to ensure correct function.
7. The user should adopt a maintenance programme for valves depending on frequency of use and application particulars. DPL recommends seal replacement at least every two years.

DISMANTLING PROCEDURE

1. Ensure that all of the **IMPORTANT** points listed on the left side of this page have been addressed prior to commencing work on your valve.
2. Remove the actuator if fitted, noting the drive coupling / valve ball position for correct re-assembly.
3. Using a suitable size spanner / wrench, loosen and remove the 4 body bolts on each of the three valve port flanges (12 bolts in total).
4. Remove the flanges from the valve body.
4. Remove the PTFE seals and ball from the body.
5. If a handle is fitted, this should now be removed.
6. Slacken and remove the stem nut.
7. The stem can now be removed by gently pushing it down from above and into the valve body.
8. The PTFE stem packing can now be removed if required and all other PTFE seats / seals can be replaced as necessary.

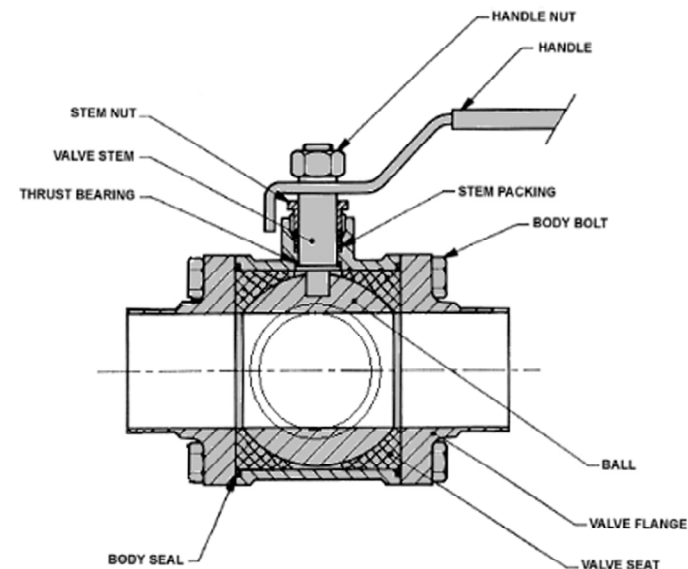

ASSEMBLY PROCEDURE: The assembly procedure is the dismantling procedure in reverse order. Take care when assembling the valve as the PTFE seals are easily damaged. The following precautions should be taken:

9. Upon re-assembly it is very important to ensure that the valve ball is correctly orientated. The 'T' or 'L' path through the valve ball should correspond with the 'T' or 'L' marked on the valve stem. This marking is located on top of the valve stem.
10. The stem nut should be tightened adequately, but not over-tightened. Use only enough force to form a seal, do not use excessive force as this will crush the PTFE stem packing. Turn the valve stem then re-adjust accordingly.
11. When re-fitting the valve centre section between the valve flanges, always ensure cleanliness of the mating faces.
12. With the valve centre section back in-place, the body bolts should be gradually tightened. Tighten each bolt a little at a time. Tighten the bolts diagonally, one flange at a time, so that an even pressure is applied.
13. Ensure that the bolts are fully tight. Keep fingers clear of moving parts and operating the valve open / closed to check for correct operation. Re-fit the actuator (if required) or handle. Ensure that the valve is in the correct open / closed orientation on re-fitting, as noted in step 2 and step 9 of this procedure.
14. Valves should be pressure tested with water, if possible, following maintenance. Follow your in-house test procedures accordingly, the valve maximum operating pressure is 10 bar.



www.dpluk.co.uk

a stainless **technologies** company

Call us: 01799 58 2440 email us: dairypipelines@dpluk.co.uk

Visit us at: www.dpluk.co.uk Unit 1, Dencora Park, Shire Hill, Saffron Walden. CB11 3GB