

Non ASME BPE Products



a  stainless **technologies** company

Gaskets

K738 White Viton Gasket Type 1

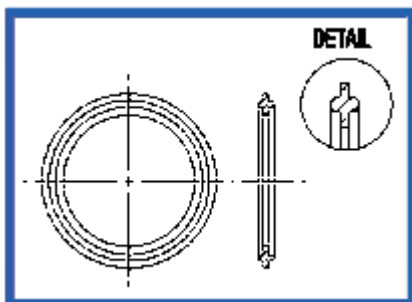

Size (ins)	Part Code
0.5	K738 05 08G
0.75	K738 07 08G
1.0	K738 10 08G
1.5	K738 15 08G
2.0	K738 20 08G
2.5	K738 25 08G
3.0	K738 30 08G
4.0	K738 40 08G

K837 Nitrile Gasket Type 1

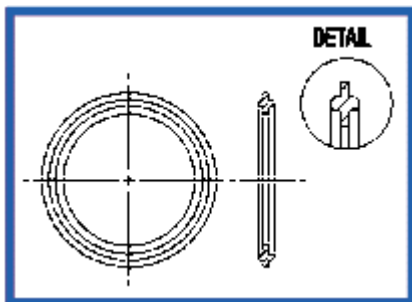

Size (ins)	Part Code
1.0	K837 10 08G
1.5	K837 15 08G
2.0	K837 20 08G
2.5	K837 25 08G
3.0	K837 30 08G
4.0	K837 40 08G

K852 EPDM Gasket Type 1

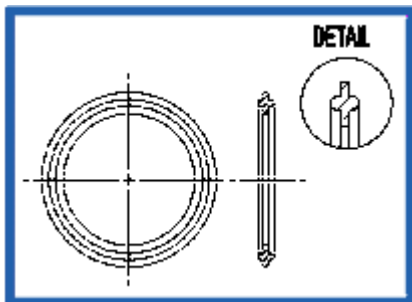

Size (ins)	Part Code
0.5	K852 05 08G
0.75	K852 07 08G
1.0	K852 10 08G
1.5	K852 15 08G
2.0	K852 20 08G
2.5	K852 25 08G
3.0	K852 30 08G
4.0	K852 40 08G

**K839 Silicone Gasket
Platinum Cured
Type 1**

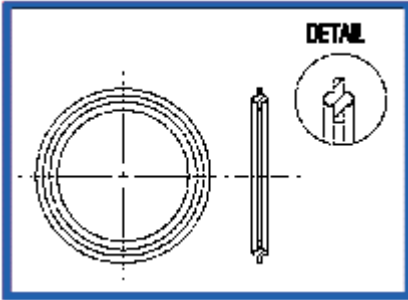

Size (ins)	Part Code
0.5	K839 05 08G
0.75	K839 07 08G
1.0	K839 10 08G
1.5	K839 15 08G
2.0	K839 20 08G
2.5	K839 25 08G
3.0	K839 30 08G
4.0	K839 40 08G

K829 Solid Teflon Gasket

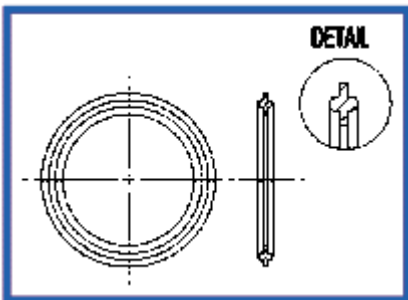

Size (ins)	Size Code
0.5	05 10G
0.75	07 10G
1.0	10 10G
1.5	15 10G
2.0	20 10G
2.5	25 10G
3.0	30 10G
4.0	40 10G

**K831 Envelope Gasket Viton Inner K828
Envelope Gasket EPDM Inner**

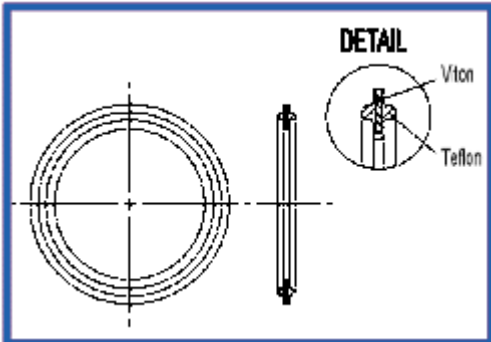

Size (ins)	Size Code
0.5	05 10G
0.75	07 10G
1.0	10 10G
1.5	15 10G
2.0	20 10G
2.5	25 10G
3.0	30 10G
4.0	40 10G

**K737 White Viton Gasket
Type 2**

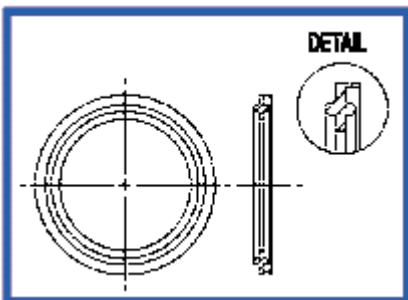

Size (ins)	Size Code
1.0	10 08G
1.5	15 08G
2.0	20 08G
2.5	25 08G
3.0	30 08G
4.0	40 08G

K834 Green Viton Gasket Type 2

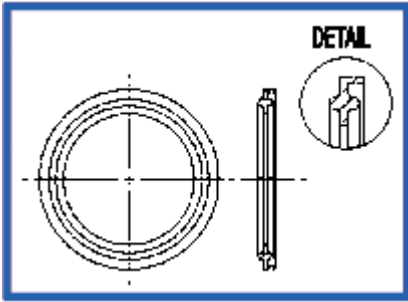

Size (ins)	Size Code
0.5	05 08G
0.75	07 08G
1.0	10 08G
1.5	15 08G
2.0	20 08G
2.5	25 08G
3.0	30 08G
4.0	40 08G

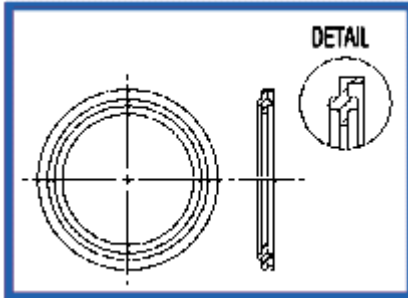

K830 Nitrile Gasket Type 2

Size (ins)	Size Code
1.0	10 08G
1.5	15 08G
2.0	20 08G
2.5	25 08G
3.0	30 08G
4.0	40 08G

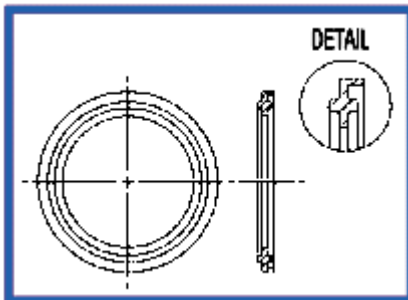

K832 EPDM Gasket Type 2

Size (ins)	Size Code
1.0	10 08G
1.5	15 08G
2.0	20 08G
2.5	25 08G
3.0	30 08G
4.0	40 08G

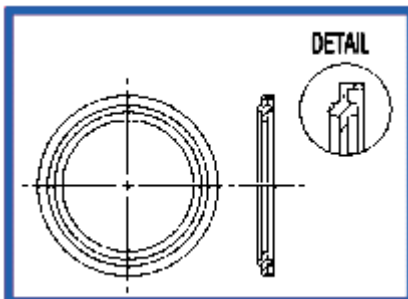

K835 White Silicone Gasket Type 2

Size (ins)	Size Code
1.0	10 08G
1.5	15 08G
2.0	20 08G
2.5	25 08G
3.0	30 08G
4.0	40 08G

All materials are approved by: 3A, USDA, and comply with FDA's Code of Federal Register - Title 21, Part 177.

Material	EPDM	VITON	SILICONE	PTFE
Temperature	-50 to 150°C	+30 to 250°C	-90 to 200°C	-25 to 250°C
Acid	Good to Ex.	Good	Good	Excellent
Vegetable Oil	Good (most)	Excellent	Poor to Good	Excellent
Petroleum Oil	Poor	Excellent	Good	Excellent
Steam	Good	Good	Good	Excellent
Abrasion Resist.	Good	Good	Poor	Excellent

PTFE GASKETS - LIMITED USE NOTE

PSI Service Ratings for clamps DO NOT APPLY to 1" and above connections incorporating PTFE gaskets. PTFE is virtually incompressible and tends to "cold flow" under normal operating conditions. PTFE gaskets, when used with any standard clamp, are likely to leak at pressures below the published service ratings.

To avoid possible leakage problems, we recommend consulting SFL before considering the use of PTFE material. This limitation does not apply to 0.5" and 0.75" Tube OD fittings and connections, due to the recessed, full-containment design of Fractional end connections.

ENVELOPE GASKETS

Consists of a PTFE outer jacket sandwiching a viton insert thus imparting some compressibility together with the excellent heat and steam resistant properties.

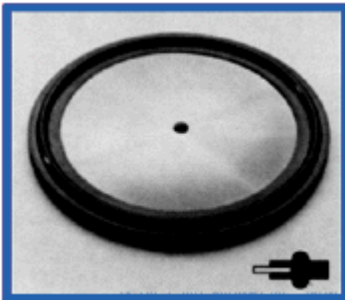

K186 Orifice Plate- Viton S/S

Size (ins)	Part Code
1.0	K186 10 08G
1.5	K186 15 08G
2.0	K186 20 08G
2.5	K186 25 08G
3.0	K186 30 08G
4.0	K186 40 08G

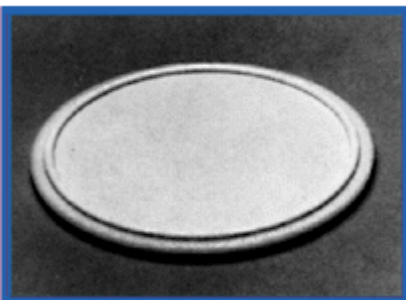

K772 Orifice Plate- Solid PTFE

Size (ins)	Part Code
0.5	K772 05 10G
0.75	K772 07 10G
1.0	K772 10 10G
1.5	K772 15 10G
2.0	K772 20 10G
2.5	K772 25 10G
3.0	K772 30 10G
4.0	K772 40 10G

**K747 Screen Disk -Viton
(Standard = 10 Mesh)**

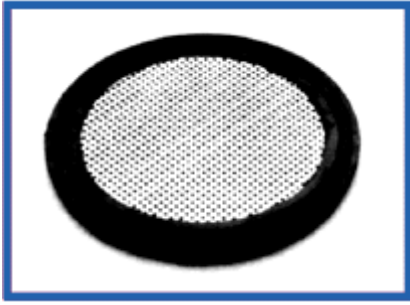

Size (ins)	Part Code
1.0	K747 10 08G
1.5	K747 15 08G
2.0	K747 20 08G
2.5	K747 25 08G
3.0	K747 30 08G
4.0	K747 40 08G

****PLEASE STATE MESH SIZE REQUIRED ****

K773 Screen Mesh -Viton



Size (ins)	Part Code
1.0	K773 10 08G
1.5	K773 15 08G
2.0	K773 20 08G
2.5	K773 25 08G
3.0	K773 30 08G
4.0	K773 40 08G

Stainless Fittings. Tipton Road, Dudley, West Midlands DY1 4SQ

Tel: +44 (0)121 557 1188

E-mail: stainlessfittings@sfluk.co.uk www.sfluk.co.uk