



a  stainless **technologies** company

Diamond Slimline Ball Valves

The **Diamond SLIMLINE Ball Valve** is a high quality, compact, on/off unit offering you space-saving.

- Unobstructed full bore means low pressure drop and no puddling.
- Full flow - suitable for pigging
- Machined from 316L forgings offering good corrosion resistance and no porosity.
- Fully machined.
- Patented body alignment ring is easily assembled and installed.
- Anti blow-out stem for safe operation.
- Viton energised PTFE stem seal is self compensating for pressure and temperature. Other seal materials also available.
- Low torque actuation offers you cost benefits.
- Available with any fitting or flange to suit your requirements.

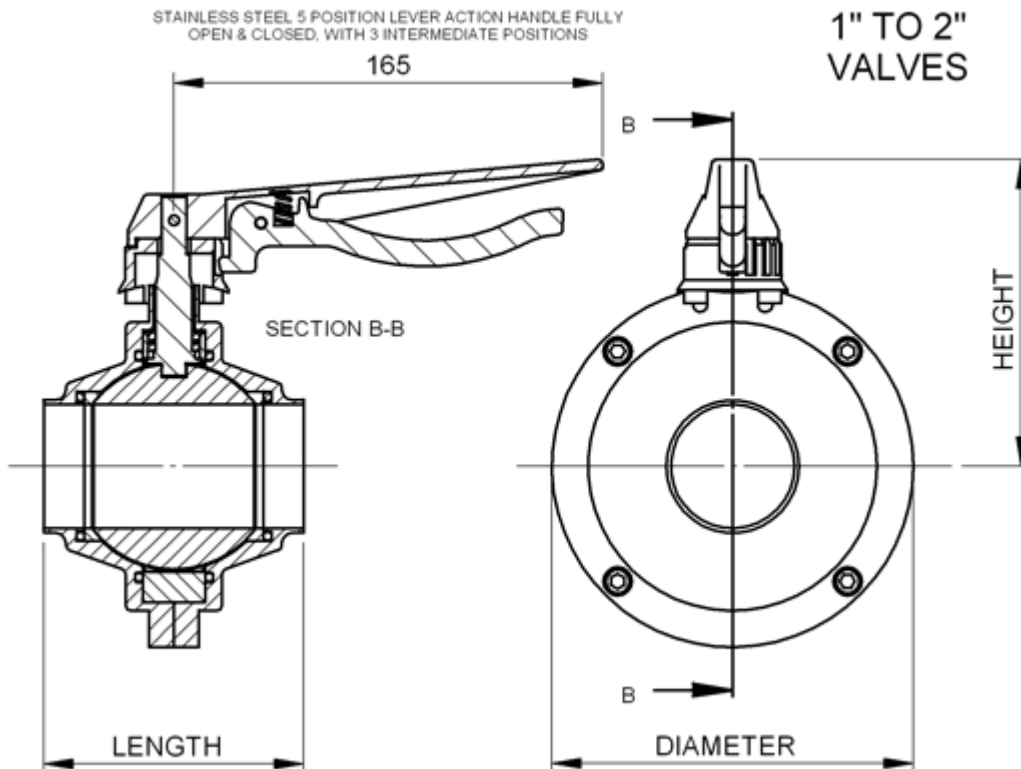

SIZE	1.0"	1.5"	2.0"	2.5"	3.0"
LENGTH - BUTT WELD (mm)	70	80	100	120	140
HEIGHT (mm)	100	110	120	150	165
DIAMETER (mm)	100	119	139	178	198
A (mm)	102	111	121	-	-

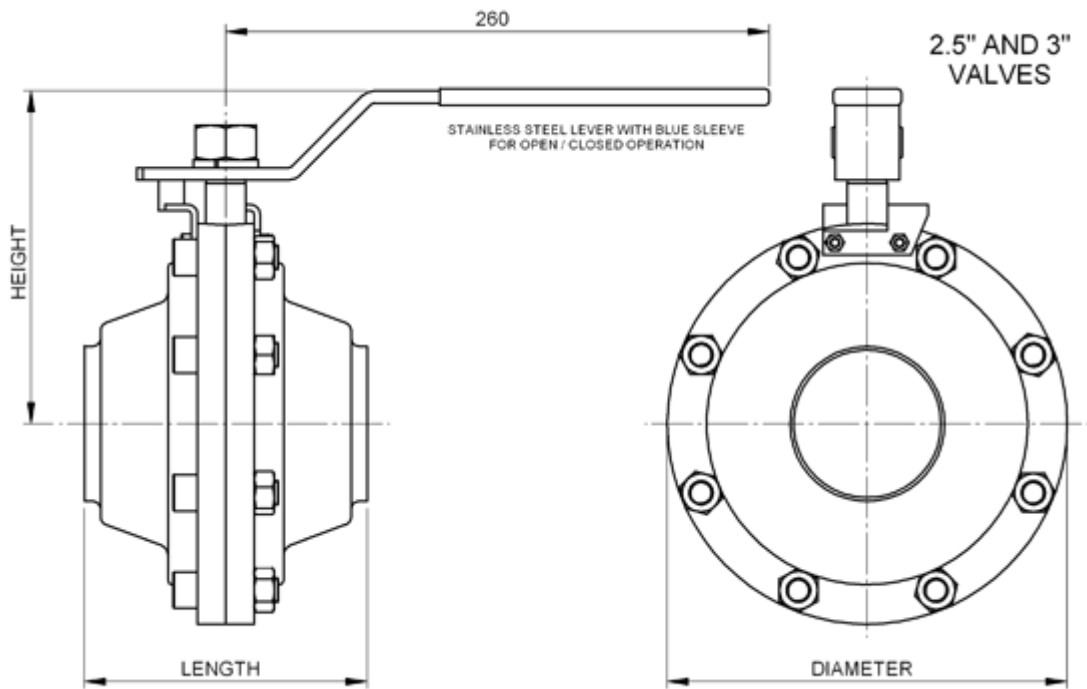

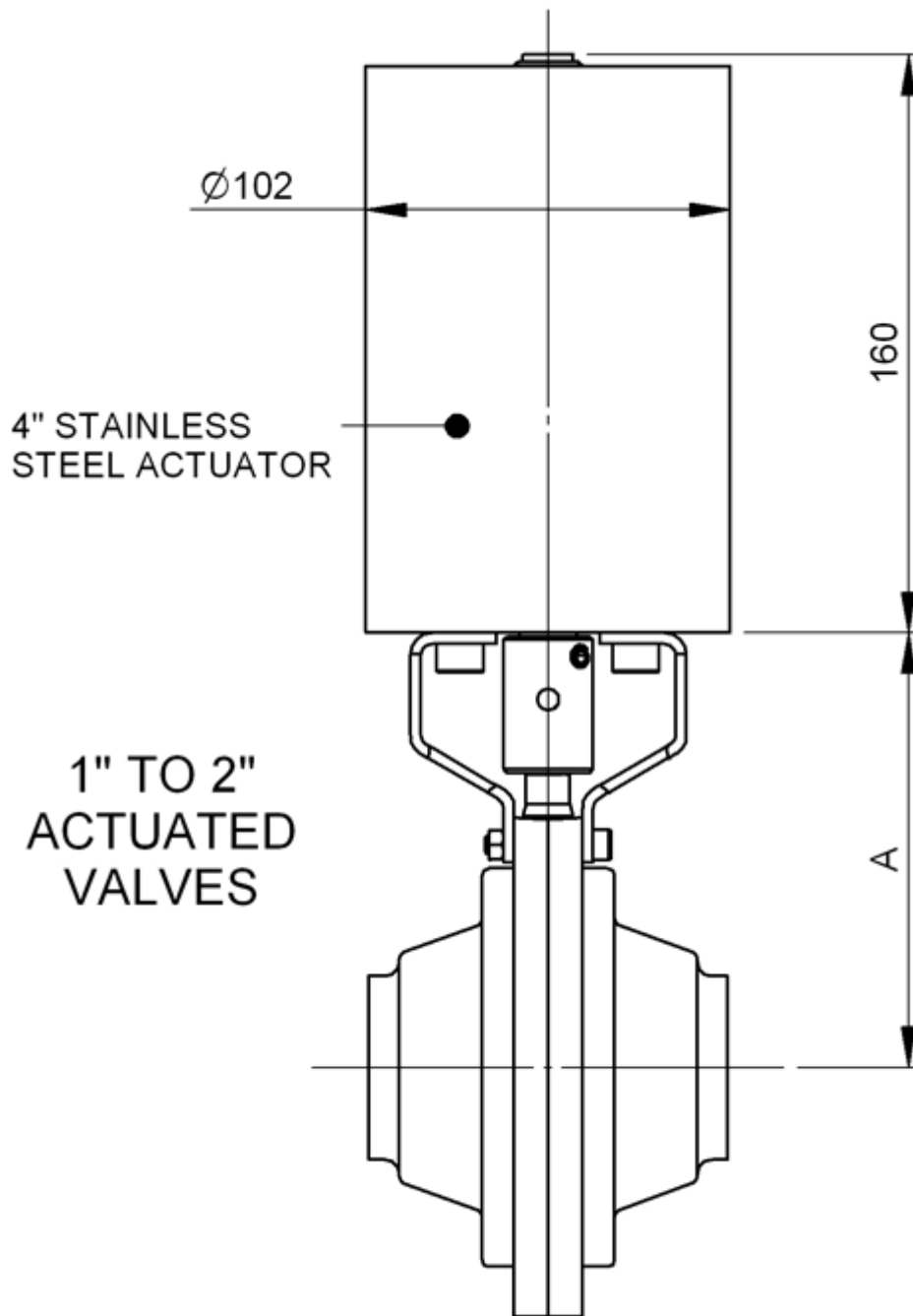

Actuation and Control

SLIMLINE Ball valves can be supplied fitted and tested with a comprehensive range of pneumatic and electric actuators including all ancillary equipment such as solenoids, limit switches and positioners.

Working temperatures dependent upon choice of seal material, please consult DPL if in doubt

Technical Data

Seat Material: PTFE

Standard Internal Finish: <1.0uM

Maximum Operating Pressure: 10 Bar

Wetted Part Construction: 316L Stainless Steel

Standard End Connections: Butt Weld, RJT, IDF, Clamp, ILC, Flange (other options available upon request)

Dairy Pipe Lines Ltd. Tipton Road, Dudley. DY1 4SQ
Tel: +44 (0)1799 522 885
Email: dairypipelines@dpluk.co.uk **www.dpluk.co.uk**