



a stainless technologies company

Diamond Non-Return Valves

The DPL hygienic Diamond Non-Return Valve is designed to prevent back-flow of product in the pipework system.

The valve is constructed to the highest specification, thus ensuring optimum levels of hygiene and cleanliness by nature of its design.

Stainless Steel product contact components are manufactured from 316 and 316L. Seals and elastomers carry FDA approval. All valve component parts are designed to enable thorough in-line cleaning, even in the most challenging of applications.

With options of surface finish, seal material and fitting type, the valve is suited to many industry sectors. These sectors include Food and Beverage, Pharmaceutical, Biomedical and Chemical.

Please call us to further discuss your requirements. We are confident that we have a valve designed to suit your application.

- ATEX approval for use in hazardous areas. (Please see information below)
- Fully machined valve components offering excellent corrosion resistance and no porosity.
- Aseptic design ensures wide acceptance in world-wide pharmaceutical, food and beverage industries including biomedical applications e.g. WFI
- Clamp body design ensures minimal downtime when sterilising / dismantling.
- Wide selection of seal material and end fittings available, thus ensuring compatibility with your system.

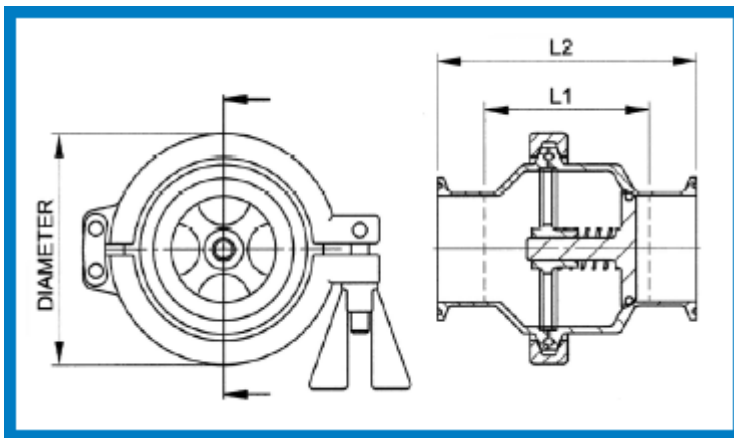

Size	0.5"	0.75"	1"	1.5"	2.0"	2.5"	3"	4"
L1 Weld	75	75	60	75	75	75	75	119
L2 Clamp	87	87	102	117	117	117	117	161
L2 Male 1DF/RJT	NA	NA	102	117	117	117	117	161 RJT 179 IDF
Diameter	63	63	63	93	107	133	145	185
Weight	0.57	0.55	0.65	1.10	1.30	1.85	2.15	4.85

Weight (kg) includes clamp ferrules, dimensions in mm

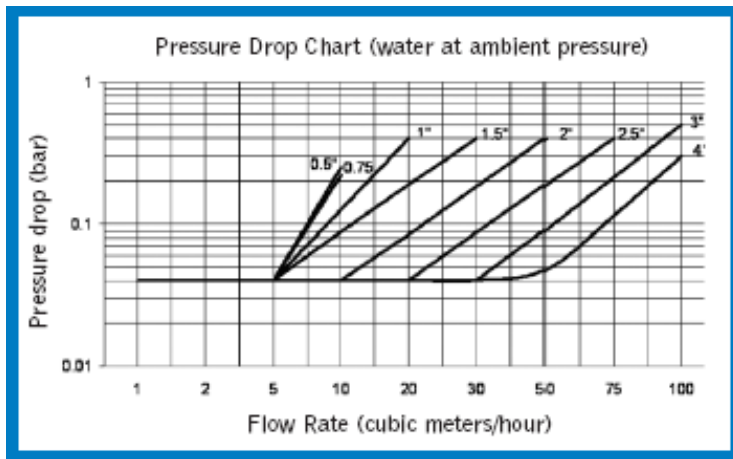

Technical Data

Initial Opening Pressure:	0.5 - 3psi
Fully Open Pressure:	1 - 4 psi
Max Operating Pressure:	150 psi (10 Bar)
Seal Material Options:	EPDM (standard), Nitrile, Silicone, Viton, FEP/PTFE
End Connection Options:	Clamp, RJT, IDF, ILC, DIN, SMS, Flange, Butt Weld
Internal Surface Finish:	0.8um (standard) 0.5um and/or Electro-Polish.
Certification:	EN10204 3.1, ATEX, P.E.D 97/23/EC(SEP)

Working temperatures dependent upon choice of seal material, please consult DPL if in doubt



ATEX approved version available for use in potentially explosive atmospheres.

Group 2, Category 2, Gas and dust compliant

Dairy Pipe Lines Ltd. Tipton Road, Dudley. DY1 4SQ
 Tel: +44 (0)1799 522 885
 Email: dairypipelines@dpluk.co.uk **www.dpluk.co.uk**