

Handrailing

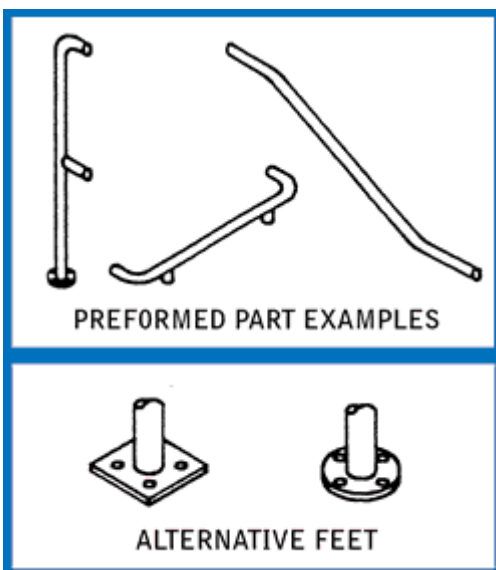

Handrail manufacture to customer specification or DPL design. Supplied as complete assembly, fully welded and polished or as preformed parts ready for on site assembly. Tube with prefabricated pullups or profiled ends for saddling. Square or round flange feet for base or wall mounting. Available tube diameters: 1.0", 1.25", 1.5", 2.0". Larger diameters available on request. Material: 304 or 316 Stainless Steel. Finish: Polished 180 grit as standard.

Dairy Pipe Line Ltd, Unit 1, Dencora Park, Shire Hill, Saffron Walden, Essex CB11 3GB.
Tel: +44 (0)1799 522 885 | Fax: +44 (0)1799 525 916
Email: dairypipelines@dpluk.co.uk **www.dpluk.co.uk**

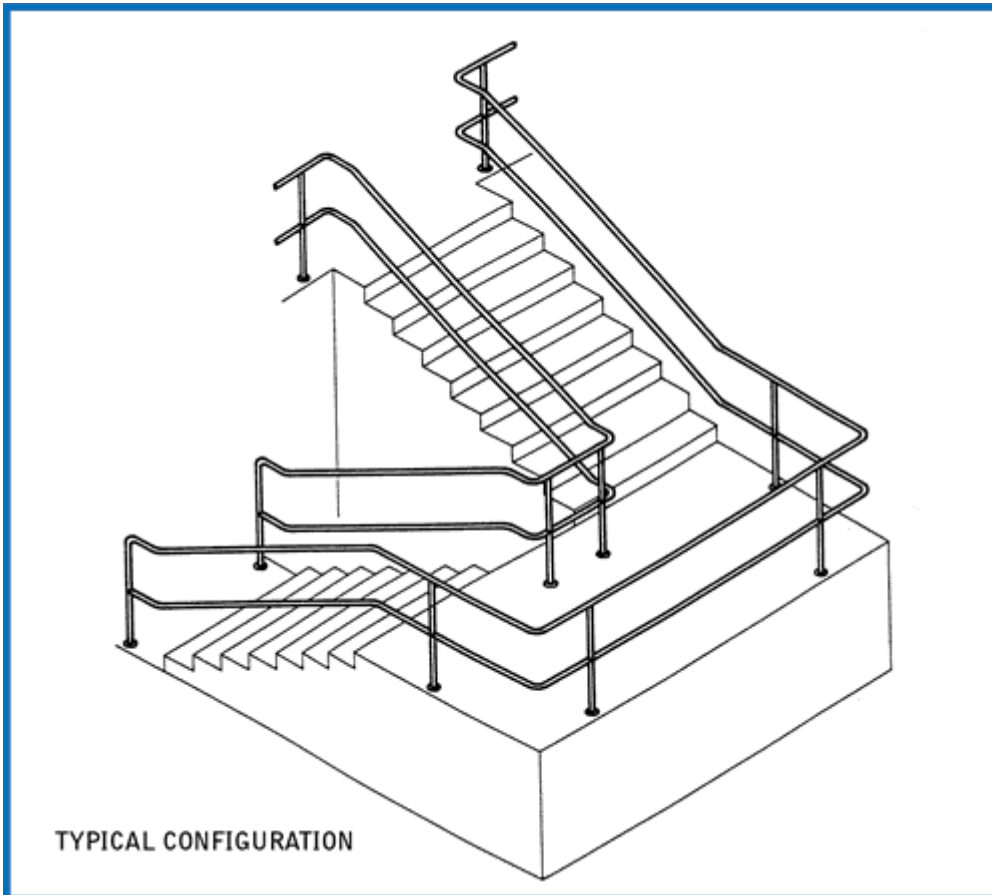